

TYPE: PROJECT: CATALOG#: LED GROW LIGHT



## Product Features

GRW-HB17 is a LED grow light bars which designed to stimulate growth with life span of 50,000 hours & IP 65 - protected against humidity and dust.

## Product Specifications

Model	GRW-HB17-450	GRW-HB17-600
Power Consumption (W)	450 W	600 W
LED Spectrum	Full Spectrum/ Horticulture	
Photon Efficiency	AVG: 2.2 - 2.5 $\mu\text{mol}/\text{J}$ , up to 2.7 $\mu\text{mol}/\text{J}$	
Beam Angle	120°	
Dimensions	$\varnothing$ 454 x 245 mm	
Input Voltage	90-305V AC, 347V AC	
IP Rated	IP65	
Weight	12 kg	
Operating Temperature	-30°C ~ 50°C	



## Technical Drawing

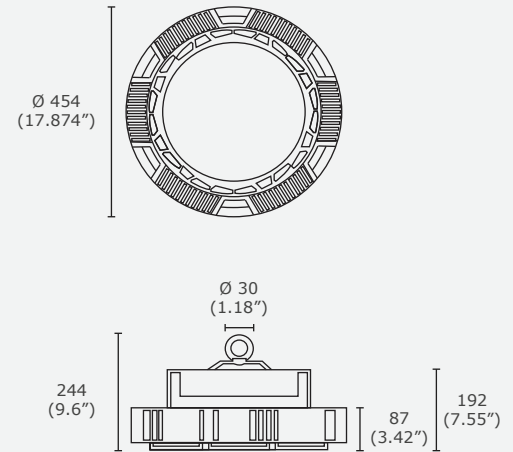

GRW-HB17

Units in Metric

## Order Form

GRW	-	-	-	-
Series	Model	3	4	5

2. MODEL	3. WATTAGE	4. VOLTAGE	5. COLOUR SPECTRUM
HB17 HB17	450 450 W 600 600 W	A 90-305V AC B 347V AC	FS Full Spectrum H Horticulture